

Section 9

Body Check, Paint, and Interior Liners

Procedures covered in this section:

Assemble body apart from airframe and check overall fit; remove tail boom; fit and install eyebrow windows; fit and install interior liners; prep and paint body and tail boom.

Cards used in this section:

E32 CARD 1T

Prints used in this section:

E32-2000

Templates used in this section:

None

Tools required for this section:

Air or electric drill	Drift punch	Mallet
Band saw or hacksaw	Files	Painting equipment
Cleco	Grease pencil or marker	Pop rivet gun
Cleco pliers	Grinder	

Drill bits of the following sizes: 3/32", 1/8", 5/32"

Ratchet with sockets of the following sizes: 3/8", 7/16", 1/2", 9/16"

Wrenches of the following sizes: 3/8", 7/16", 1/2", 9/16"

Notes:

1. **BODY CHECK:** During the body check, the seat bulkhead, floor pan, and body panels are re-assembled apart from the airframe to check and refine the overall fit. This is a good time to install the interior liners. The body check can be done any time after the body has been assembled and before it is painted. As the remainder of the aircraft is being assembled, some of the fiberglass parts will need to be re-installed more than once so that other components can be fitted; for example, the seat bulkhead must be installed to determine fuel tank location.
2. **TAIL BOOM:** The tail boom can be sanded and painted along with the body panels. Scotchbrite works well for sanding the tail boom.

AIRFRAME AND LANDING GEAR

BODY CHECK

Photo #1

Re-assemble the body panels, seat bulkhead, and floor pan on the ground. Protect the bottom of the body by resting it on cardboard or other padding. Check all panels for fit, and finish any sanding or trimming if necessary.



EYEBROW WINDOWS

Photo #2

Fit the eyebrow windows. Trim around the edges as necessary so that the window fits into the recess in the fiberglass panel. Drill holes for 12 screws, evenly spaced around each window.



Photo #3

If desired, mask off the inside of the window and paint the outside edge, using the same paint as used for the body.

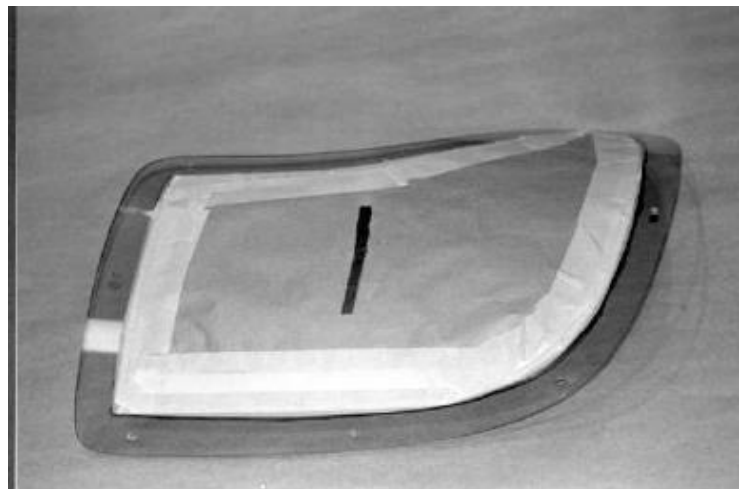



Photo #4

Install the finished eyebrow windows using 6-32 screws, nuts and washers.

INTERIOR LINERS

Photo #5

The interior liners have a black gel coat finish which is ready for installation as supplied. They can also be painted a different color or covered with fabric if desired. The liners are supplied in four pieces:

1. E32-1321 EYEBROW, PILOT
2. E32-1331 EYEBROW, PASSENGER
3. E32-1341 FORWARD, PILOT
4. E32-1351 FORWARD, PASSENGER

If any of the windscreen or eyebrow window screws interfere with the installation of the liners, the ends of the screws may be trimmed off. Use a hand grinder with an abrasive wheel, bolt cutters, or a hacksaw.

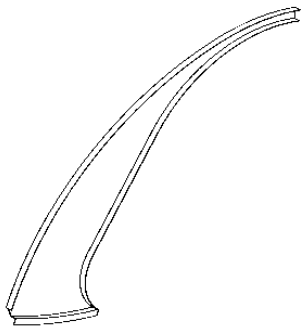
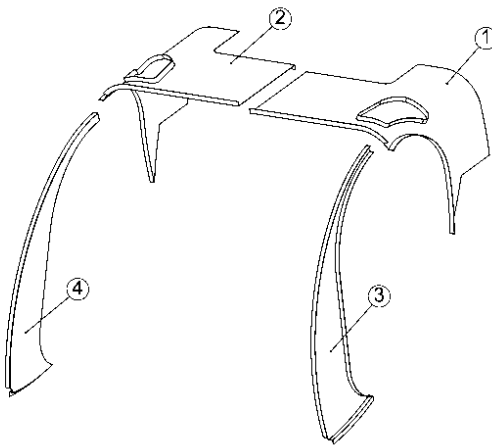

Photo #6

Fit the forward liners first. Trim the lower front corner as necessary. Trim and sand edges to get the desired fit around the door openings. The lower lip of the liner goes between the floorpan and tub.

Photo #7

The forward liners are secured to the windscreen bracing panels with countersunk screws and nut plates. Drill 1/8 inch holes through the liner and the windscreen bracing panel in the 3 places shown. Use clecos to hold the liner in place while trimming and fitting. When a good fit is achieved, install the nut plates on the liners. Countersink the corresponding holes in the bracing panel for the 8-32 screws. E00-1205. Hardware on E32 CARD 1T.

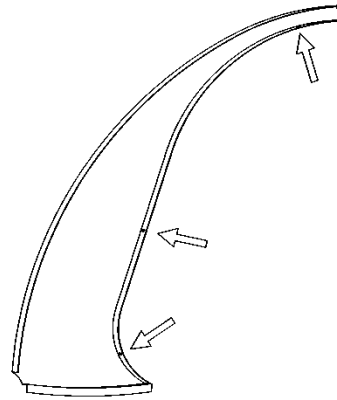

Photo #8

This shows a nut plate installed on the back of the liner.

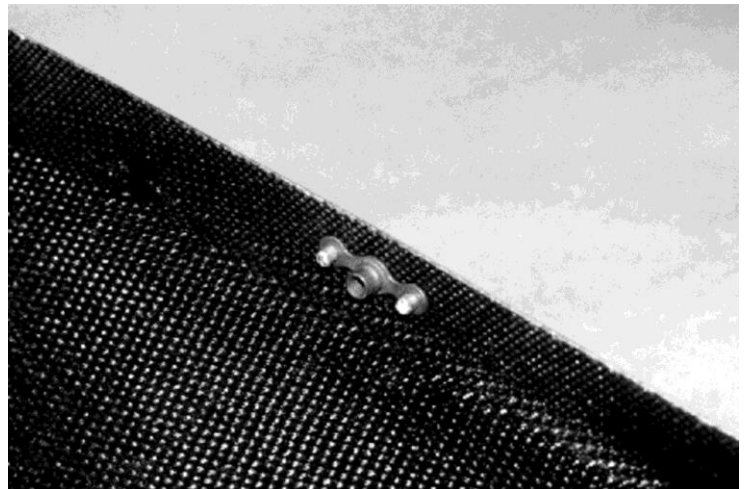
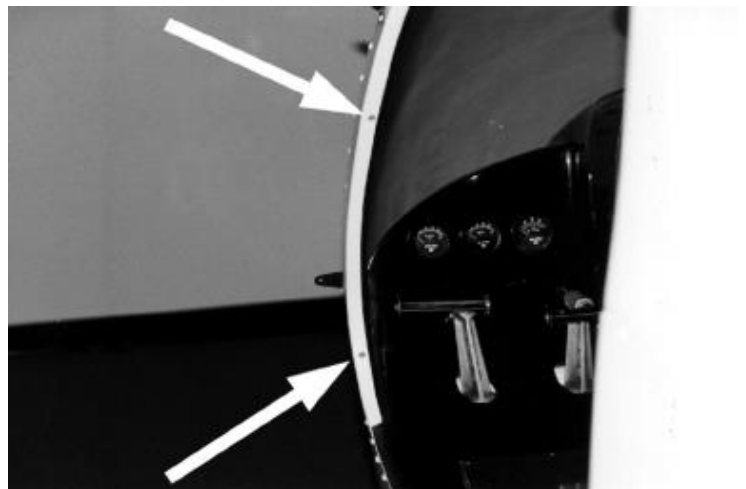

Photo #9

When installed, only the heads of the countersunk screws should be visible.



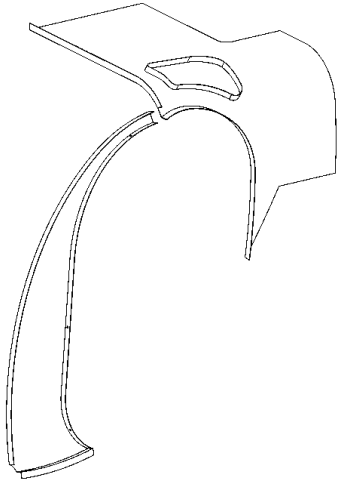

Photo #10

Cut a notch in the eyebrow liner as shown. The narrow part of the forward liner should extend beyond the cutout and be covered by the eyebrow liner.

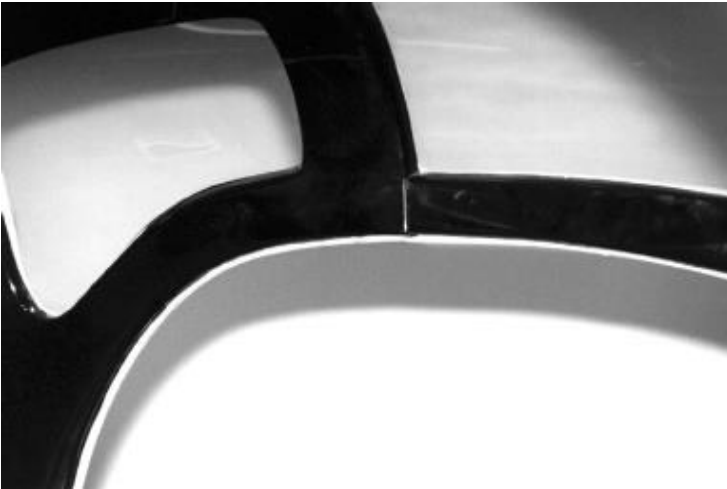

Photo #11

View from inside showing the eyebrow liner overlapping the forward liner.

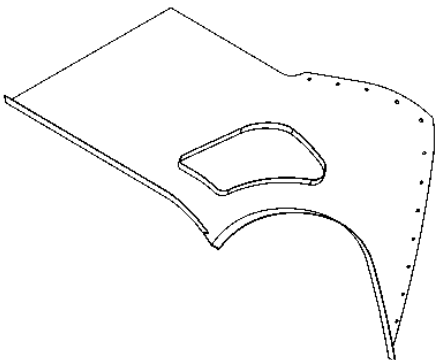

Photo #12

Place the rear of the eyebrow liner between the seat bulkhead and the body panel. When a satisfactory fit is achieved, transfer the position of the screw holes from the body to the liner. The holes may be drilled slightly oversized to allow for some misalignment. Trim off excess material.

Photo #13

The eyebrow liners may butt together or overlap where they meet at the top. Cut an opening in the eyebrow liners for clearance of the overhead wiring. The size of the opening should be the same as the inside of the fiberglass overhead switch cover. When installed, the switch panel will hold the liners in place at the top. The front edge will be held up by the headset bracket.



Photo #14

Install screws and nut plates to hold the liners in place where the windscreen bracing panel meets the upper fuselage cowling at the top of the door opening.

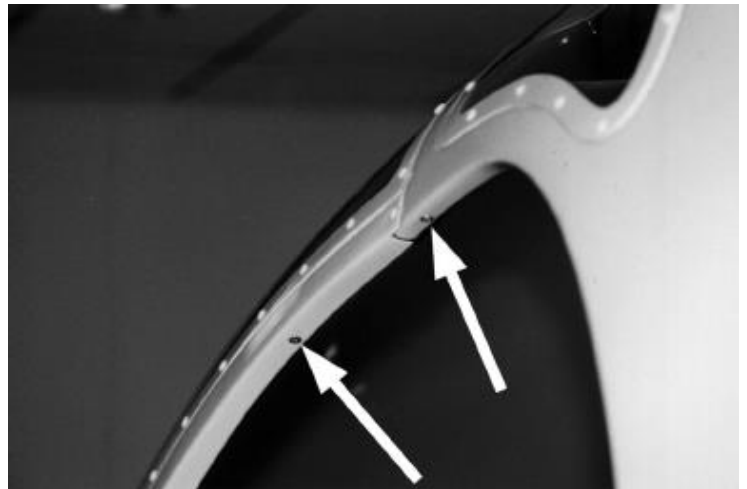
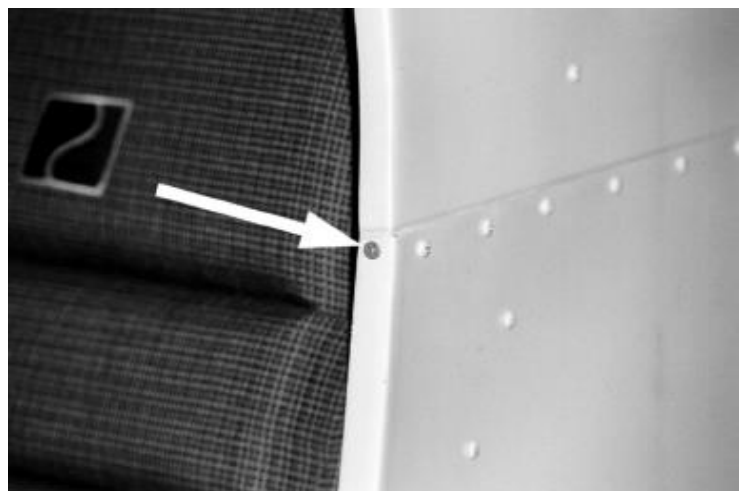

Photo #15

Install screws and nut plates to hold the liners in place at the seam of the body panels on the rear edge of the door opening.





PAINTING

Photo #16

Fill any hole or noticeable depression with fiberglass resin prior to sanding.



Photo #17

Final sand body panels with 400 grit sandpaper and then lightly with 600 wet and dry paper. Use plenty of water. It is desirable to achieve a smooth satin finish on the fiberglass panels before painting.

We recommend the use of a two part polyurethane paint for the body and tail boom. This paint will give the best chance for the novice painter to achieve a beautiful and long lasting finish, with a minimum of effort or experience. Polyurethane paints are readily available and come in a variety of colors. Follow the instructions provided with the paint you purchase for its application. When purchasing paint, be sure to buy a primer that is compatible. If the fiberglass surfaces have been finished properly before priming, the primer coat will require very little if any sanding before final painting. We recommend painting the panels and tail boom when they are disassembled. In this manner all the overlapping areas will have a coat of paint. After final body assembly, mask off and paint the trim scheme of your choice.